

Fog / Jet Monitor

FJM - FJF/SLN

Datasheet 1011/175

Page 1 of 2

(replaces datasheets 1011/138-147)

General description

Powerful fire extinguishing monitor with exceptional performance characteristics. Remote or manual operation, including fog/jet pattern control. The FJF nozzle is manually adjustable for flows from 5,000 l/min to 20,000 l/min. The SLN monitor has an automatic nozzle that can handle a variable flow range from 5,000 l/min or 20,000 l/min at a constant inlet pressure

Application description

Intended for fixed mounting, it is designed for an optimised delivery of water or foam from a solid jet to a fog pattern by remote control.

The FJF nozzle is commonly used where variable flows are required and encountered due to the water supply or when a water and foam monitor are combined into one unit. The nozzle can be remotely set for the designated flow during operation.

The SLN uses an automatic nozzle, often used for marine FiFi 1 class systems where an additional foam capability is required.

This system is used preferably with the Skum Inline foam inductor. The manually operated FJM-200 FJF can be used on FiFi tugs or mounted on trailers.

Product features

- Remote control or manual operation
- Adjustable flow to nominal capacity of 20,000 l/min
- Fulfils the requirements of FiFi 1 class
- Compact, balanced design
- Low weight
- Easy to operate due to low friction bearing
- Long throw length of 130 metres
- Adjustable stream pattern
- Corrosion resistant construction
- Available with EEx(e) and (de) electrical equipment
- Manual override as standard



FJM-200 EL FJF

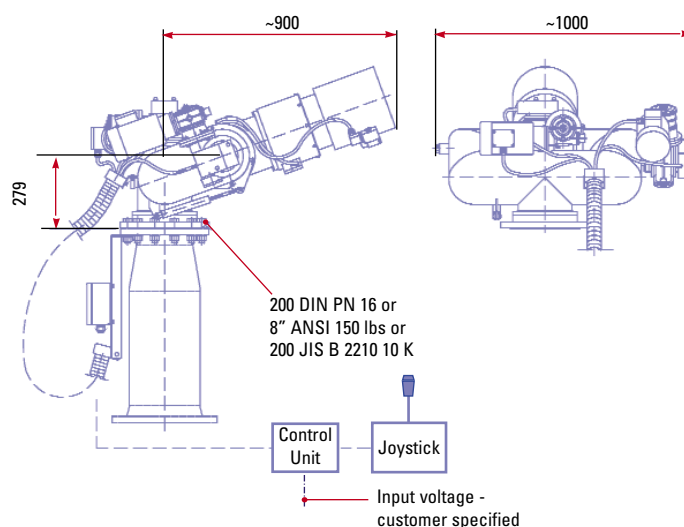

Performance Data

FJM-200 EL FJF / SLN

Type	FJM-200 EL FJF	FJM-200 EL SLN
Water capacity	5,000 - 20,000 l/min	
Inlet connection	200 DIN PN16 or 8" ANSI 150 lbs	
Design pressure	13 bar	13 bar
Rotation	± 165°	±165°
Elevation	-10° to +70°	-60° to +70°
Weight	150 kgs / 331 lbs	130 kgs / 287 lbs

1 bar = 0,1 MPa = 14,5 psi



www.skum.com

tyco Fire Suppression & Building Products

Technical changes reserved without notice Copyright © 2007 Tyco Safety Products

Datasheet Ref. SKM0004b DSA1

Fog / Jet Monitor

FJM - FJF/SLN

(replaces datasheets 1011/138-147)



Connections

- Foam/water inlet: flanged according to 200 DIN or ANSI 150 lbs

Optional components

- Power supply from 12V DC to 440V AC available.
- Control and operating panel, choice of configuration or custom built as per FiFi requirements.
- Foam proportioning system using Around the pump proportioners (PI), Inline Inductors (MI) or Pump Proportioners (PP).

Listings and approvals

- Det Norske Veritas (DNV)
- Bureau Veritas (BV)
- Russian Maritime Register of Shipping
- Now certified by Lloyds Register of Shipping (LRS)

FJM-200 EL SLN

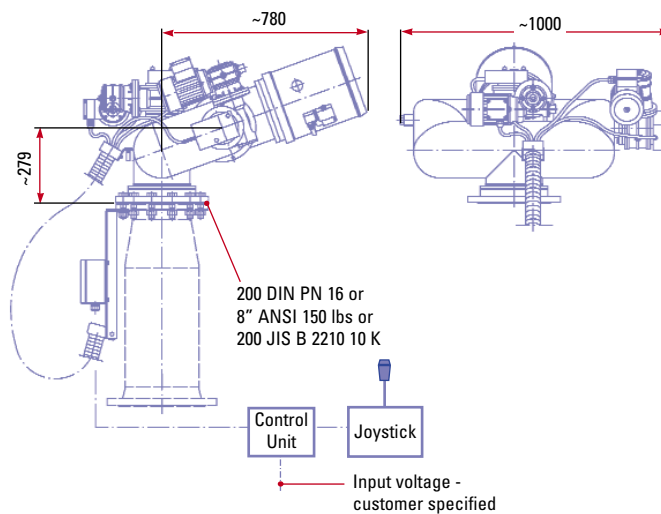

FJM-200 SLN / FJF Monitor - Range of Jet

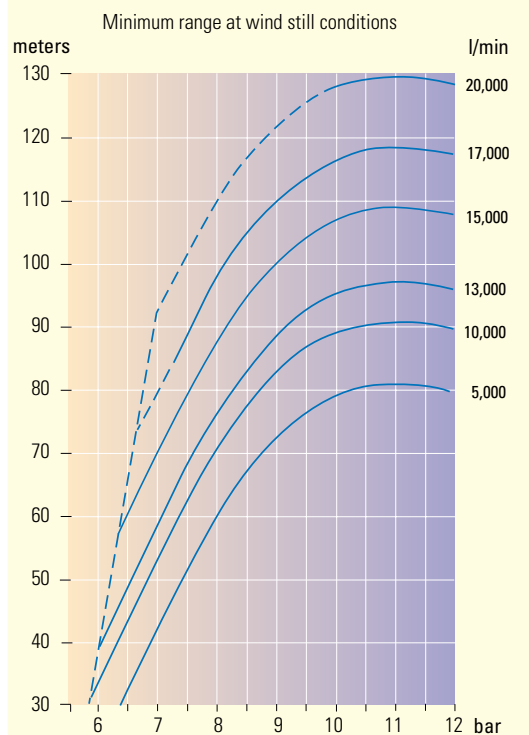

Reaction force (N) = 0.233 x Q (l/min) x √p (bar)

FJM Monitors - Average Fog Pattern (in still air)

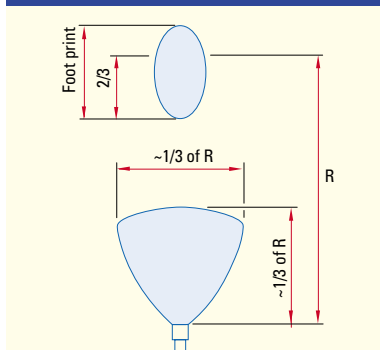

Manually operated FJM-200 FJF

Performance Data

Manually operated FJM-200 FJF

Water capacity	5,000 - 20,000 l/min
Inlet connection	200 DIN PN16 or 8" ANSI 150 lbs
Design pressure	13 bar
Rotation	± 180°
Elevation	-10° to +70°
Weight	130 kgs / 287 lbs

1 bar = 0,1 MPa = 14,5 psi



www.skum.com

tyco Fire Suppression & Building Products